



INTERNATIONAL APPLICATION PUBLISHED UNDER THE PATENT COOPERATION TREATY (PCT)

<p>(51) International Patent Classification ⁶ : G06F 19/00, H04N 1/41</p>	<p>A1</p>	<p>(11) International Publication Number: WO 98/19263 (43) International Publication Date: 7 May 1998 (07.05.98)</p>
<p>(21) International Application Number: PCT/IL97/00349 (22) International Filing Date: 29 October 1997 (29.10.97) (30) Priority Data: 119523 30 October 1996 (30.10.96) IL (71) Applicant (for all designated States except US): ALGOTEC SYSTEMS LTD. [IL/IL]; Hamelacha 4, P.O. Box 2408, 43000 Raanana (IL). (72) Inventors; and (75) Inventors/Applicants (for US only): BENJĀMIN, Menashe [IL/IL]; Yehoda Halevi Street 75, 43555 Raanana (IL). ELAD, Michael [IL/IL]; Einstein Street 45, 34603 Haifa (IL). BAR-SELA, Ran [IL/IL]; Technion, 32000 Haifa (IL). REICHMAN, Yosef [IL/IL]; Kineret Street 14, 44201 Kfar-Saba (IL). MARGOLIN, Jacob [IL/IL]; Herut Street 7, 52541 Ramat-Gan (IL). (74) Agents: FENSTER, Paul et al.; Fenster & Company, Patent Attorneys, Ltd., P.O. Box 2741, 49127 Petach Tikva (IL).</p>	<p>(81) Designated States: AL, AM, AT, AU, AZ, BA, BB, BG, BR, BY, CA, CH, CN, CU, CZ, DE, DK, EE, ES, FI, GB, GE, GH, HU, ID, IL, IS, JP, KE, KG, KP, KR, KZ, LC, LK, LR, LS, LT, LU, LV, MD, MG, MK, MN, MW, MX, NO, NZ, PL, PT, RO, RU, SD, SE, SG, SI, SK, SL, TJ, TM, TR, TT, UA, UG, US, UZ, VN, YU, ZW, ARIPO patent (GH, KE, LS, MW, SD, SZ, UG, ZW), Eurasian patent (AM, AZ, BY, KG, KZ, MD, RU, TJ, TM), European patent (AT, BE, CH, DE, DK, ES, FI, FR, GB, GR, IE, IT, LU, MC, NL, PT, SE), OAPI patent (BF, BJ, CF, CG, CI, CM, GA, GN, ML, MR, NE, SN, TD, TG). Published <i>With international search report. Before the expiration of the time limit for amending the claims and to be republished in the event of the receipt of amendments.</i></p>	

(54) Title: DATA DISTRIBUTION SYSTEM

(57) Abstract

An interactive system for obtaining data for diagnostic purposes from a server having access to stores of said data wherein the server supplies the data and software to a data requesting user that enables the user to receive the data progressively so as to decide during the receipt of the data what portions of the data are to be received thereby decreasing the time required to receive the data and that enables the user to load the software to process the supplied data.

FOR THE PURPOSES OF INFORMATION ONLY

Codes used to identify States party to the PCT on the front pages of pamphlets publishing international applications under the PCT.

AL	Albania	ES	Spain	LS	Lesotho	SI	Slovenia
AM	Armenia	FI	Finland	LT	Lithuania	SK	Slovakia
AT	Austria	FR	France	LU	Luxembourg	SN	Senegal
AU	Australia	GA	Gabon	LV	Latvia	SZ	Swaziland
AZ	Azerbaijan	GB	United Kingdom	MC	Monaco	TD	Chad
BA	Bosnia and Herzegovina	GE	Georgia	MD	Republic of Moldova	TG	Togo
BB	Barbados	GH	Ghana	MG	Madagascar	TJ	Tajikistan
BE	Belgium	GN	Guinea	MK	The former Yugoslav Republic of Macedonia	TM	Turkmenistan
BF	Burkina Faso	GR	Greece	ML	Mali	TR	Turkey
BG	Bulgaria	HU	Hungary	MN	Mongolia	TT	Trinidad and Tobago
BJ	Benin	IE	Ireland	MR	Mauritania	UA	Ukraine
BR	Brazil	IL	Israel	MW	Malawi	UG	Uganda
BY	Belarus	IS	Iceland	MX	Mexico	US	United States of America
CA	Canada	IT	Italy	NE	Niger	UZ	Uzbekistan
CF	Central African Republic	JP	Japan	NL	Netherlands	VN	Viet Nam
CG	Congo	KP	Kenya	NO	Norway	YU	Yugoslavia
CH	Switzerland	KG	Kyrgyzstan	NZ	New Zealand	ZW	Zimbabwe
CI	Côte d'Ivoire	KP	Democratic People's Republic of Korea	PL	Poland		
CM	Cameroon	KR	Republic of Korea	PT	Portugal		
CN	China	KZ	Kazakistan	RO	Romania		
CU	Cuba	LC	Saint Lucia	RU	Russian Federation		
CZ	Czech Republic	LI	Licchtenstein	SD	Sudan		
DE	Germany	LK	Sri Lanka	SE	Sweden		
DK	Denmark	LR	Liberia	SG	Singapore		
EE	Estonia						

DATA DISTRIBUTION SYSTEM**FIELD OF THE INVENTION**

This invention is concerned with interactive communication systems linking central locations having access to stores of data and images used for medical purposes and a plurality
5 of outlying users of the images and data for medical review, processing, assessment and diagnostics.

BACKGROUND OF THE INVENTION

Modern hospitals and health centers today usually have several computerized systems for medical information gathering, exchange, storage and processing. Herein such a system is
10 referred to as a "data source". Medical information may come in textual, voice, sound, graphical, and image modalities. Such medical information may be required by authorized personnel, including those located outside the hospital premises, and equipped with computers of some sort. Herein the requiring side is referred to as the "user". In present systems the users are equipped with their own software to access the data source. Difficulties in the use of such
15 computerized systems are caused by such things as the varied networking procedures required to fetch the data, the lack of an industry standard, the lack of an easy to use user interface and, in the case of image data transfer, the channel bandwidth requirements along with the typically large volumes of the image information, which in turn translates into very long transmission periods. In addition to that, a typical user might be required to master the skills of operating a
20 large number of software systems like those used with various data processors, the varied communication software, software installations procedures, etc. The system administrator needs to install the different types of application software in large numbers of computers, and update this software, in each computer, every time a new version is used. This proliferation of software and hardware in the medical data processing systems make such systems difficult to
25 maintain and a burden to update.

Presently, more and more hospitals and clinics are uniting for economic reasons to form healthcare enterprises with consolidated resources, having a single headquarters for managing the organization. The consolidation of resources also takes place inside individual hospitals, with the primary goal of facilitating data exchanges inside the hospital, with hospital
30 personnel outside the hospital premises, as well as with other related facilities and with the enterprise headquarters. Generally, most individual facilities that make up the enterprise operate special systems to store and manage various parts of their clinical data. One can

generally view these systems as being composed of data acquisition devices, data storage devices (data banks), and data management and communication modules. The users are connected to the data banks via various networking procedures and communications protocols. These users may operate a variety of computer hardware systems. Access of each user to stored patient data is presently done through the use of special application software on the user's computer. Since presently, most health and medical organizations have constructed their information systems and communications network over a period of time, access to these systems is often complicated, and sometimes requires the user to master several application, software and communication protocols. Typically, no common access method or user interface is available to the user, and users are often confined to the use of particular hardware at a specific location to access the data. The need to access image data further complicates the situation. The large bandwidth required from the communications link, the large data volumes, and the special processing that is usually needed, often requires the use of special software and hardware on the user's side .

Thus, one problem encountered with the present server-user communication systems for transferring medical data is the many different interfaces, software applications, and communication protocols required and the many different types of work stations that make up the "installed base". Due to this proliferation of different work stations requiring different software applications, interfaces and communications protocols, then whenever a new improved system or a new data type become available, the many different work stations have to be equipped with the software for utilizing the new systems or data. This is not only expensive, but time consuming in that the installation of the software in each of the many different work stations and the central server requires time and usually requires expertise beyond that of the doctor or medical professional using the workstation.

A second and equally troublesome problem is encountered when the data requested by the user includes images that must be transmitted over a given enterprise network. This is due to the long time required for transmitting image data as compared to other forms of data. Image compression is used to reduce transmission times. For clinical image data, special precautions must be taken if lossy compression is implemented, due to the potential loss of possibly vital findings. Lossless compression schemes are therefore employed, which provide a relatively small reduction of image transmission time (a factor of 2-3 for radiology images). Interactive compression schemes, that optimize the transmission time for any given user and

user type are currently not available in existing healthcare information systems. Such an interactive compression scheme is presented as part of this invention.

The above can be summarized in a conceptual diagram (Fig. 1). An enterprise wide healthcare information system 11 may be conceptually conceived as comprising several local facilities, 12-14, connected to a central facility 16. Each local facility comprises data sources 17 connected through appropriate interfaces such as interface 18, to the local network, to which the various local users 19 are connected too. The local network of each local facility is in turn connected to the central facility through another interface (possibly including firewalls and security features). The central facility comprises a similar structure, with the addition of central repositories 23, data bases, and data management tools. This structure of the presently available systems suffers from the problems described above. Thus those skilled in the art are still searching for effective solution to the existing problems.

BRIEF DESCRIPTION OF THE INVENTION

This invention provides systems and methods for largely overcoming the above problems, among other things, by adding data distribution servers, such as local server 24 and central server 26 as indicated in Fig. 2. The concept detailed in Fig. 2 is logically summarized in Fig. 3. The various clinical data acquisition devices and data banks are conceptually grouped into a "data source" block 28. A server 29 is introduced as an intermediate level between the data source and the users. The introduction of the server, with the appropriate functionality and data handling algorithms, alleviates many of the problems presented above.

While the concept and method introduced here is applicable for the distribution of any type of clinical and non-clinical information, this invention will focus on solving the problem of distributing clinical images over the network, which poses one of the major obstacles in implementing a complete and comprehensive healthcare clinical information system.

The present medical image data communications and networking system overcomes the above described and other problems by providing an interactive and efficient method for a user to obtain images for diagnostic, review and processing purposes from a server having access to a plurality of stored images. The method comprises the following steps:

- connecting a user's computer to a server over a communications networks,
- interfacing the computer and the user (e.g. installing an industry standard browser software, such as Netscape, Explorer, etc., on the user's computer),

- using a program in the server to receive from the server special software (applet) for the user's computer necessary for data selection and processing,
- selecting data for transmission from the server to the user's computer,
- compressing the data for transmission by selectively using either lossy or loss-less compression algorithms,
- 5 - progressively transmitting the requested data over the network,
- receiving and decompressing the compressed data using the applet and producing preview images of progressively improving resolution, and
- using the preview images for selecting parts or a subset of the images for continued transmission to reduce the required transmission time.

10 The above enumerated and other problems are overcome, by using, for example, the Internet to connect the user and the server. The user's computer does not need any software for receiving or processing the requested image except the standard browser software. Instead, the necessary software is transmitted from the server along with the image using a network computing language such as Java or ActiveX or similar language. Accordingly, if and when

15 there are changes or improvements made in the data, the software or the image processing procedure, it is no longer required for a technician to go and install the necessary software or modify the existing software on each user's computer. Instead this is accomplished using the Java or ActiveX type language.

20 The second problem, that is the time required for transmitting of images is overcome by progressively sending "layers" of the data so as to make preview images which are not necessarily of high resolution quality, but as more and more layers of data are sent the resolution progressively improves. The user will be able to decide to get only a certain portion (Region of Interest - ROI) of the image rather than the whole image, or to entirely discard the

25 image by stopping the transmission. In addition, based on the preview images, the user may decide to request only a subset of an image set. Further time savings result from using segmentation whereby background in the image is automatically detected and omitted. Also, a lossy compression can be used for the preview image, and upgrading to full resolution and quality can be done on specific request. Therefore, in the process of image viewing, much less

30 data may be transmitted than in the present systems and time savings can be considerable. This greatly alleviates the problem faced when transmitting clinical images from a server to a user for diagnostic purposes.

Hence, the system described herein overcomes the above mentioned difficulties by applying a coding scheme which includes lossy and loss-less algorithms, with pyramidal structuring of the images for progressive transmission. A simple yet general man to machine interface (MMI) enables the user to activate the compression algorithms interactively, according to on-line requirements. Today's network computing software (such as Java or ActiveX) enable a simple procedure by which the user's software is installed by a networking service program on the server, and there is no installation requiring user intervention on the user side (except a one time installation of an industry standard browser software).

A sample compression-decompression scheme for the treated images to be used on a wide range of communication networks is presented. This scheme can treat both volumes (group of images) and single images applying loss-less or lossy coding, according to requirements posed by the user and the available resources. A progressive approach is applied within the compression-decompression scheme, which enables the user to get previews or overviews of the transmitted image long prior to the time required to transmit the entire image. The quality of the overviews improves over time thus enabling the user to get basic impressions of the transmitted data long before the entire image has arrived. The basic impressions enable the user to interact with the server so that only the actually necessary data is really sent to the user. A typical session of requesting a medical image from a medical image store involves a series of decisions regarding image and region of interest selection. The progressive, interactive approach enables the user to make many of these decisions before the entire image-set is received. This further reduces the time required to get the needed images and improves the resource utilization by transmitting, in full description, only that part of the data which is really of interest.

The compression-decompression scheme is designed to be asymmetric, namely, the computational requirements on the server/coding side are much greater compared to the requirements on the user/decoding side. This is in accordance with the assumption that the server's side of the system is implemented on a relatively powerful computer while the user's hardware requirements are minimal (the user's work station can also be a simple Personal Computer).

The coding scheme described herein utilizes various properties of the typical medical images, for coding benefit. Medical images often contain an informative part surrounded by a background which is of less medical importance. The proposed coding scheme takes

advantage of this particular image structure by using segmentation of the image prior to transmission, in order to avoid transmitting the information-less background. The background information is coded and transmitted only upon a specific user's request and/or after the informative part of the images has arrived at the user.

5 Medical images are typically acquired using more than 8 bits per pixel. Many if not most of potential users are only able to display color or gray level information at 8 bits per pixel. For that reason a lossy version of the image can be obtained by dynamic range reduction using simple well known techniques generally referred to as "windowing", or more complicated adaptive techniques, such as adaptive "windowing". Those lossy image versions
10 are much smaller in size than the original image and can be transmitted relatively fast, enabling the user to display a lossy version of the image in a short time. This lossy version serves as a preview or overview image and also as a basis for further improvements of image quality. As an overview image it enables the user to decide what part of the image set and image region is really required. The interactive nature of the user/server protocol enables the
15 client to dynamically specify which part of the image set is needed. Only the needed part will be fully transmitted; thus, reducing the required transmission periods.

Because of the progressive nature of the coding schemes, the images at the user's side are available for on-line processing during transmission. Various enhancement, display, and analysis techniques are supported. Interactive graphics on the user's side enables the viewer to
20 define a region of interest in order to confine the transmission to that specific area.

It should be understood that, in a preferred embodiment, the interactive communication system also interfaces to clinical information systems available to the server enabling the transfer of data that includes, for example, medical reports, medical history, laboratory results and test results.

25 There is therefore provided in accordance with a preferred embodiment of the invention, an interactive method for allowing a user to obtain image data for diagnostic purposes from a server having access to stored data, comprising:

connecting a user's computer to the server over a communication network;
receiving from the server image reconstruction software for the user's computer;
30 requesting specific image data for transmission from the server to the user's computer;
progressively transmitting the requested specific image data over the network from the server to user's computer; and

reconstructing a diagnostic quality image, from the image data, using the reconstruction software.

Preferably, the method comprises image processing said reconstructed image using said reconstruction software. Alternatively or additionally, the method comprises:

5 receiving from the server image selection software for the user's computer, wherein said image selection software is used for said requesting. Preferably, said image selection software controls the transmission of the image data.

Alternatively or additionally, said image selection software displays images from said server. Alternatively or additionally, said image selection software and said reconstruction
10 software are received together. Alternatively or additionally, said image selection software and said reconstruction software comprise a single software unit. Alternatively or additionally, said image selection software is operative to stop the transmission of the data. Preferably, said image selection software is operative to restart the transmission of the data, after said stopping.

In a preferred embodiment of the invention, said image selection software controls
15 processing of data at said server, prior to its transmission. Preferably, said processing comprises reducing said data from a large bit-per-pixel ratio to a small bit per pixel ratio.

Alternatively or additionally, said image selection software controls said server to selectively transmit only portions of the image data. Alternatively or additionally, the method comprises interactively providing user input to said image selection software, to affect said
20 control.

Alternatively or additionally, the image selection software comprises application software coded using a device independent network programming language.

Alternatively or additionally, the reconstruction software comprises application software coded using a device independent network programming language.

25 Preferably, said language comprises Java. Alternatively, said language comprises ActiveX.

In a preferred embodiment of the invention, reconstructing comprises:

reconstructing images of progressively improving quality from the progressively received data;

30 using the produced improved images of progressively produced quality to decide on processing of the images; and

processing said images, prior to the progressively received data being completely received.

Alternatively or additionally, reconstructing comprises:

5 reconstructing images of progressively improving quality from the progressively received data;

using the produced improved images of progressively produced quality to decide on processing of the images; and

interactively selecting regions of interests in the images based on said progressively improved images, prior to the progressively received data being completely received.

10 There is also provided in accordance with a preferred embodiment of the invention, an interactive method for allowing a user to obtain image data for diagnostic purposes from a server having access to stored data, comprising:

connecting a user's computer to the server over a communication network;

requesting specific image data for transmission from the server to the user's computer;

15 progressively transmitting the requested specific data over the network to the user's computer;

reconstructing images of progressively improving quality from the progressively received data;

20 using the produced images of progressively produced quality to decide on processing of the images; and

processing said images, prior to the progressively received data being completely received.

25 There is also provided in accordance with a preferred embodiment of the invention, an interactive method for allowing a user to obtain image data for diagnostic purposes from a server having access to stored data, comprising:

connecting a user's computer to the server over a communication network;

requesting specific image data for transmission from the server to the user's computer;

30 progressively transmitting the requested specific data over the network to the user's computer;

reconstructing images of progressively improving quality from the progressively received data;

using the produced improved images of progressively produced quality to decide on processing of the images; and

interactively selecting regions of interests in the images based on said progressively improved images, prior to the progressively received data being completely received.

5 In a preferred embodiment of the invention, said image data represents a set of images and wherein said using the produced images to decide comprises using the produced images to decide on processing images which have not yet been received.

10 In a preferred embodiment of the invention, the method comprises deciding on a termination of transmission of said progressive image data, responsive to said reconstructed images. Alternatively or additionally, said processing comprises converting said image data to image data representing an image with fewer bits per pixel. Alternatively or additionally, said processing comprises selecting a region of interest of said images. Alternatively or additionally, said processing said images is performed on said image data, at said server, prior to their being transmitted to said user's computer.

15 There is also provided in accordance with a preferred embodiment of the invention, an interactive method for allowing a user to obtain data for diagnostic purposes from a server having access to stored data, said method comprising:

connecting a user's computer to the server over a communication network;
receiving from the server reconstruction software for the user's computer;
20 requesting specific data for transmission from the server to the user's computer;
progressively transmitting the requested specific data over the network;
progressively receiving the data using the reconstruction software to process the received data and produce images of progressively improving quality; and
25 using the produced progressively improved images to decide on further transmission of the image data.

There is also provided in accordance with a preferred embodiment of the invention, an interactive method for allowing a user to obtain image data for diagnostic purposes from a server having access to stored data, comprising:

connecting a user's computer to the server over a communication network;
30 requesting specific image data for transmission from the server to the user's computer;
reducing the bit-per-pixel ratio of parts of the data being transmitted, responsive to said request; and

transmitting the reduced data.

Preferably, said reduction in bit-per-pixel ratio is performed responsive to user input at said user's computer. Preferably, said user input comprises selection of an image portion.

In a preferred embodiment of the invention, reducing the bit-per-pixel ratio comprises:

5 calculating an average "M" of the gray values in the image and a standard deviation "S" of said gray values; and

rescaling these values in the range $[(M-S/2)..(M+S/2)]$ to obtain a new lower number of bits per pixel.

Alternatively, reducing the bit-per-pixel ratio comprises:

10 estimating the mean and standard deviation of the gray levels locally; and

rescaling these values to obtain a new lower number of bits per pixel.

In a preferred embodiment of the invention, progressively transmitting the requested data over the network comprises:

15 recomposing the image into a pyramidal structure comprised of layers, said layers ranging sequentially from a layer having the least amount of data to a layer having the most data; and

transmitting the layers making up the pyramid individually starting with the layer with the least amount of data to enable the user to view the progressively improving image to decide on further transmission of the image.

20 Preferably, recomposing the image into a pyramidal structure comprises reducing the image to provide the different layers at the transmitting end for progressive transmittal. Preferably, reducing comprises discarding alternate rows and columns to create an image that is a quarter of the size of the original image.

In a preferred embodiment of the invention, the method comprises:

25 providing a first layer with reduced resolution in the pyramidal structure; providing remaining layers that contain residual values with increased resolution; and progressively receiving the data using to provide images based on the received data of progressively improved resolution.

In a preferred embodiment of the invention, the method comprises:

30 compressing the requested data transmitted over the network; and decompressing the received required data to provide images.

Preferably, compressing comprises spatially decorrelating the data by predicting each pixel at the current resolution using its spatial casual neighbors. Alternatively, compressing comprises temporally decorrelating each pixel by predicting each pixel value at the current resolution using the values of temporal neighbors from previous images. Preferably, a
5 predictor X used in predicting each pixel for a single image is equal to $f(a,b,c)$, where a , b and c are previously predicted neighboring pixels.

Alternatively, a predictor X used in predicting each pixel for a group of images equals $f(a,b,c,a1,b1,c1,x1)$ where a , b and c are previously predicted neighboring pixels in a same image and $a1$, $b1$, $c1$ and $x1$ are corresponding pixels in a previously predicted image of the
10 image group.

In a preferred embodiment of the invention, said compressing and said decompressing use entropy coding and decoding respectively. Preferably, said entropy coding and decoding are accomplished using Golomb Rice entropy coding and decoding.

In a preferred embodiment of the invention, the method comprises using adaptive
15 slicing and entropy coding and decoding of each slice for progressively transmitting the requested specific image data, wherein said entropy coding generates a residual matrix.

Preferably, using adaptive slicing comprises:

scanning the obtained residual matrix into a residual vector; and
partitioning the residual vector into variable length sub vectors with a relatively
20 homogeneous probability distribution function.

Preferably, partitioning comprises:

estimating the local mean and variance on the sub-vector;
sectioning the vector on high transients; and
coding each sub vector separately.

25 Alternatively or additionally, said compression does not increase the size of said data.

In a preferred embodiment of the invention, connecting the user computer to the server over a communication network comprises connecting over the Internet. Alternatively, connecting the user computer to the server over a communication network comprises using a dial up communication system. Alternatively, connecting the user computer to the server over
30 the communication network comprises using networking facilities.

Alternatively or additionally, the stored data comprises data for a plurality of "postage stamp" images. Preferably, the method comprises using "postage stamp" images as a catalog

for selecting those images for which no further data is to be transmitted and those images for which further data is to be transmitted. Alternatively or additionally, said postage stamps comprise a lowest level in a pyramidal representation of said images.

5 In a preferred embodiment of the invention, the method comprises stopping the transmission at the user's request. Preferably, the method comprises restarting the transmission at the user's request.

10 In a preferred embodiment of the invention, progressively transmitting comprising serially transmitting a sequence of images. Alternatively or additionally, progressively transmitting comprising transmitting data operative to reconstruct images of increasing resolution.

In a preferred embodiment of the invention, progressively transmitting the requested data over the network comprises segmenting an image into background parts and tissue parts, and transmitting the tissue parts first.

15 There is also provided in accordance with a preferred embodiment of the invention, an interactive method for allowing a user to obtain image data for diagnostic purposes from a server having access to stored data, comprising:

connecting a user's computer to the server over a communication network;
segmenting an image into background parts and tissue parts; and
transmitting the tissue parts first.

20 Preferably, the method comprises requesting said specific image data for transmission from the server to the user's computer.

In a preferred embodiment of the invention, the method comprises stopping the transmission before transmitting the background part. Alternatively, the method comprises transmitting the background part to achieve loss-less transmission of the image.

25 There is also provided in accordance with a preferred embodiment of the invention, a method of adaptive slice compression, for compressing progressively transmitted multi-slice image data, which data is progressively transmitted as pyramid layers, comprising

encoding said data using entropy encoding, which encoding generates a residual matrix;

30 scanning the obtained residual matrix into a vector; and

partitioning the residual vector into variable length sub vectors with a relatively homogeneous probability distribution function.

Preferably, partitioning comprises:
estimating the local mean and variance on the vector;
sectioning the vector on high transients; and
coding each sub vector separately.

5 There is also provided in accordance with a preferred embodiment of the invention, an interactive method for allowing a user to obtain image data for diagnostic purposes from a server having access to stored data, comprising:

connecting a user's computer to the server over a communication network;
requesting specific image data for transmission from the server to the user's computer;
10 transmitting the requested specific image data over the network from the server to user's computer;
stopping said transmission, by command from a user at said user's computer; and
continuing said transmission after a time, on command from said user.

Preferably, said continued transmission is modified by said user, responsive to images
15 reconstructed from said stopped transmission. Alternatively or additionally, stopping said transmission stops compression of images at said server. Alternatively or additionally, stopping said transmission comprises stopping said transmission after a partial-resolution representation of the image data is transmitted.

There is also provided in accordance with a preferred embodiment of the invention, an
20 interactive method for allowing a user to obtain image data for diagnostic purposes from a server having access to stored data, comprising:

connecting a user's computer to the server over a communication network;
receiving from the server image reconstruction software for the user's computer;
requesting specific image data for transmission from the server to the user's computer;
25 transmitting the requested specific image data over the network from the server to user's computer; and
reconstructing a diagnostic quality image, from the image data, using the reconstruction software.

BRIEF DESCRIPTION OF THE DRAWINGS

30 For a more complete understanding of the invention, reference should be made to the following detailed description which is given in conjunction with the accompanying drawings, of which:

Figure 1 - is a conceptual representation of a present prior art enterprise wide healthcare information system,

Figure 2 - adds data distribution servers to the enterprise healthcare information system to facilitate enterprise wide data transfer,

5 Figure 3 - presents a logical representation of the data distribution server concept of fig. 2.

Figure 4 - is a general block diagram of a preferred compression-decompression scheme;

10 Figure 5 - is a showing of the reduce and enlarge operations in the pyramidal decomposition;

Figure 6 - is a showing of the pyramidal structure concept;

Figures 7a and 7b - illustrate the background transmission approach;

Figure 8 - illustrates the order of transmission;

Figure 9a - illustrates a predictor for a single image;

15 Figure 9b - illustrates a predictor for a group of images; and

Figure 10 - illustrates an example of vector partitioning.

GENERAL DESCRIPTION OF THE PREFERRED EMBODIMENT

1. System Overview

20 The system consists of a server that has access to data banks and distributes the data on demand. Several users can connect, simultaneously, to the server, over communication lines. In this system the server is also responsible for image pre-processing and for distributing user software. The user's function is to manage the medical image acquisition and processing through the use of an intuitive Man-Machine Interface, a special protocol and the available hardware and communication resources.

25 A typical medical image acquisition session will start by a simple data request, made by the user, to the system's server communication site. This generic request can be accomplished using any of standard communication protocols and, for example, through an HTTP (Hyper Text Transmission Protocol) connection to the server (which can be designed for access purposes as a Web (WWW) site. There are no requirements on the user's hardware and browser software other than the basic capability to communicate over the chosen
30 communication line and for the browser to support a network computing language such as Java or ActiveX. Using the Web, these requirements will include a link to the Internet and a

standard Web browser as described above. Upon such a request, the server will download, to the user's machine, a network application applet. This network application will serve as the user's application in all future interactions with the server. The network application is a generic, platform independent application written in a suitable network application language such as, but not limited to, Java or ActiveX. The network language may also be any other software that utilizes the communication capabilities of the user's machine. After a short authorization and authentication procedure, the user will be presented with an opportunity to request medical data. The communication can also be accomplished using "dial-up" or other "networking" schemes.

Medical data includes Medical Image Data, throughout this description. It may comprise a number of medical images, of various modalities, which are available for transmission through the server. The user may define the specific medical case of interest through the use of network application queries into the server's database. Selecting the case is done using case identifiers which are usually, but not limited to, textual, image icons, etc. A typical CT (Computerized Tomography) case may contain 50-100 medical images. The actual transmission of the medical image information is accomplished through the use of a compression/decompression algorithm and a powerful client/server protocol. The transmission is relatively fast owing to a smart utilization of the available hardware and network resources and focusing on the needed medical information by providing the user with interim information, thus letting the user refine the information query parameters during the acquisition process itself. The compression-decompression algorithm is basic to the explanation of the user/server acquisition protocol. Therefore, this general description will start with an explanation of the compression-decompression algorithm followed by a discussion of the acquisition protocol and conclude with a more detailed review of the Man-Machine Interface.

2. The Compression-Decompression Algorithm

The goal of the compression-decompression algorithm is to achieve maximal compression ratios but at the same time supply the user with visually adequate interim images. The algorithm should also support loss-less as well as lossy interim and final results, be suited to the medical image processing common to these images and as much as possible be asymmetric and easy to implement using the network computing language.

Figure 4 presents an overview of the compression-decompression algorithm for use with the system described. Compression starts by (optional) segmentation (block A1 in the figure 4), where the background of the image (if it exists) is separated from the actual image.

5 Figures 7a and 7b show graphical presentations of such possible background segmentations. The regions denoted A, B, C, and D in figure 7a are background regions. The proposed segmentation bounds the region of actual tissue by a rectangle. Only the inner part is progressively transmitted. Other methods of segmentation are possible as shown in figure 7b where the actual tissue is shown peripherally bounded by the dashed lines.

The second step (optional) in image coding for compression is a windowing operation
10 (block B1 in figure 4), where the dynamic range of the input image is reduced to a lower number of bits per pixel. The new number of bits can represent the client's display capabilities or be derived from the communication bandwidth restrictions. The windowing operation could be done, for example, by estimating the average M and the standard deviation S of the image values, and rescaling these values in the range $[(M - S / 2) .. (M + S / 2)]$ using the required
15 new number of bits. As an alternative, an improved locally adaptive windowing method can be applied, which estimates the mean and standard deviation locally. Other well known windowing procedures can be used.

Since one of the goals to be accomplished is to supply the user with meaningful interim results, the medical images are sent progressively. This requirement in turn implies that a
20 pyramidal re-structuring of the image is required (block C1 in figure 4). The concept of pyramidal decomposition of an image is shown in figure 6, where the two basic operations - Reduce and Enlarge - are further described in figure 5. The reduce operation revises or decomposes the image by, for example, simply discarding all even rows and columns, creating an array that is a quarter of the original size. The enlarge operation, for example, bilinearly
25 interpolates the image, resulting in an array four times larger. The interpolation process is not limited to a bilinear interpolation. The exact type of interpolation is selected based on the user's computational and display capabilities. The pyramidal structure contains at the zero-level one small image with reduced resolution. All the remaining levels contain residual values with increased resolution. The pyramidal decomposition of the image could also be achieved
30 through the use of other pyramidal decomposition algorithms. The pyramidal data structures consist of several versions of the original image. Each version is of different size and nature. The pyramidal information is ordered such that the top of the pyramid is the version of the

original image which least resembles the original image. If the pyramid is loss-less the final level of the pyramid is an exact replication of the original image. It is clear that after decompressing a specific level we can reconstruct the image up to that level and get an interim result. This interim result resembles the original image according to the level of the pyramid.

5 In order to facilitate an efficient coding scheme, further decorrelation of the data is required. This is achieved by spatial and temporal decorrelation operation (block D1 in figure 4). At this stage, each pixel in the current resolution level is predicted by its spatial casual (already transmitted) neighbors. If groups of images are being coded together, temporal neighbors from previous images are used to compute a second predictor, and the best
10 predictor is chosen for each block of pixels. At the end of the prediction stage, the residuals are rescanned into a vector. If the user selected only part of the image to be transmitted (ROI - Region of Interest) only that part of the residual image is scanned and the ROI parameters are added to the header of the image

Following is an example of a predictor for a single image (Fig. 9a):

$$x=f(a, b, c)= \left\{ \begin{array}{ll} \max (a, b) & c < \min (a, b) \\ \min (a, b) & c > \max (a, b) \\ a + b + c & \text{otherwise} \end{array} \right\}$$

15 Using similar reasoning a predictor for a group of images can be effective in case there is correlation between successive images (Fig. 9b):

$$x=f(a,b,c,a1,b1,c1,x1)$$

The residual vector is partitioned into variable length sub-vectors with a relatively homogeneous probability distribution function (block E1 in figure 4). The adaptive
20 partitioning is accomplished by estimating the local mean and variance on the vector, and sectioning the vector on high transients. Each sub-vector is then coded using an entropy coder. One example of such coding is a Golomb-Rice code (block F1 in Fig. 4). An example of a possible partitioning is shown in Fig. 10.

The decompression algorithm is basically the compression operations in inverse order.
25 First, a header is obtained, stating whether segmentation and/or windowing operations were applied, the size of the images and their number, the pyramid depth, etc. (block A2 in figure

4). A zeros pyramid is then constructed in order to be filled during the decoding process (block B2 in figure 4). Each sub-sector is decoded using inverse entropy coding, i.e., Golomb-Rice code (block C2 in figure 4), and all these sub-blocks are rearranged into matrix form. The spatial/temporal prediction is then computed and added to the residuals (block D2 in figure 4),
5 and the obtained values are loaded into the pyramid (block E2 in figure 4). The pyramid can be restructured to an image at any time during this operation, yielding the obtained image so far.

If segmentation is applied, the background will be transmitted at the end of the transmission of the inner image part. This is for loss-less transmission. For lossy transmission the user can stop the transmission, thus disregarding the background. Transmitting the
10 background is supported by dividing the background into four parts as indicated in figure 7a or by mapping the image as indicated in figure 7b. Each such part is raster scanned into a vector and the same coding operations presented above apply again, namely, decorrelation, adaptive sectioning, and entropy coding (i.e., Golomb-Rice coding). Other compression-decompression methods of course can be applied within the scope of this invention.

15 If windowing is applied, the received image at the user's location is a lossy representation of the original image. Upon the user's request, the error image (the difference between the original and the windowed image) should be coded and transmitted. This error image is coded using the same methodology as presented for the background transmission - decorrelation, adaptive sectioning, and entropy coding (i.e., Golomb-Rice coding).

20 For image group/series, the order of transmission is as shown in figure 8. First, all the low-resolution levels are sent. At the end of this stage, the client may view all the required images in an overview form using the basic version of the entire image set. At the second stage, each of the images is updated by sending the next resolution level. As soon as a resolution level for a specific image is received, the image can be updated to the next interim
25 version which is better than the current version. After several such steps, the images are obtained in error-less form on the user's display

Another option, instead of the loss-less entropy coding described above, may be implemented by applying the already existing JPEG routines within the browser software. This approach consists of optional (as before) windowing and/or segmentation steps, followed by a
30 pyramidal decomposition of the obtained image. Each resolution level is then compressed using the lossy JPEG algorithm. At the user, each such level is decompressed accordingly. Since lossy compression- decompression results in deeper compression ratios, and since the

decompression routines are written in the computer native language, much shorter waiting periods are obtained at the user's end. As described in detail for the windowing and segmentation operations, one final step of residuals transmission is required in order to support final loss-less representation of the original images at the user's workstation.

5 In addition to the above described techniques, other methods can be applied within the scope of the present invention. All the above are examples of the invention, which is not limited to those methods.

3. Image Acquisition Process - "Stamps"

Using the insight gained in the explanations rendered until now, the image acquisition
10 process itself can now be described in greater detail. As presented herein above, the user defines the specific medical case (patient, study, series, images) of interest through the use of network application queries into the server's database. Selecting the case is done using the case identifiers which are usually, but not limited to, text or image icons. A typical CT case may contain 50-100 medical images. Out of all these images the goal is to supply the user with
15 the images really needed for the purpose of drawing conclusions (diagnostic, second opinion, etc.) as fast as possible. Usually, out of the entire image case the user will require only a limited number of images and only a specific region of interest (ROI) in the limited number of images. Typically these requirements are case dependent and the user cannot decide which images and what part of these are really needed until the images are viewed. The protocol thus
20 should let the user specify these requirements as soon as possible by supplying the user with interim information which will arrive fast and be sufficiently adequate to make these decisions.

Upon selection of the medical image case the server starts to prepare (as an option) a very basic version of the entire medical case. This basic version of the images will be referred
25 to as "stamps" or icons and will consist of a reduced version, which is visually similar, for every image in the case. The size, in bits, of these "stamps" is small compared with the size of the original images. The entire "stamp" collection is thus a reduced representation of the entire image case. Its size is selected to enable the user to visually select which images are of interest while retaining the small total size. This will assure that the entire reduced representation of
30 the image case will arrive at the user in a relatively short time. Having presented the entire "stamp" collection to the user, the server awaits the user selection of a sub-set of the entire image case. The sub-set can include the entire case but will typically include only several

images. This sub-set of the image case will be referred to hereinafter as the "image group". In place of the icons, text can be used to describe the images.

After the user selects the image group, the server prepares a pyramidal decomposition for each and every image in the group or volume process for the whole series. If segmentation and/or windowing were selected, the server performs these operations at this stage. It then goes on and performs the rest of the compression chain (D1 through F1 in Fig.4) for the top level of the pyramid. This level is the most reduced version of the image and thus is also the smallest. As an option, the server can utilize the "icons" which have been prepared in the previous stage for this purpose. Optionally, as a first stage, only the smallest representation of the image is sent from the server to the user. The user receives and displays the images. After, or even during, this recuperation stage the user can select either a smaller sub set of the group images and/or smaller region of interest out of the image space. This serves as a finger query into the entire image data base and is sent from the user to the server over the communication line. If no finer selection is required the user is enabled to specify whether the visual level obtained so far is sufficient, thus ending the image acquisition process. However, if a better visual level is needed the acquisition process is combined to obtain the next level in the pyramid. Alternatively if the user does nothing the next level is sent. As soon as the server gets the request it performs blocks D1 through F1 on the next level in the pyramid. This is done only to those images which are required and within these images only to that part of the image which is of interest (the ROI). Within the image group the order of compression and communication is presented in Fig. 8. The protocol preferably works on a resolution first basis. All the images in the image group may be brought to the same resolution level and only then the server advances to the next resolution level. Other orders of operation can be used without losing the generality of the invention.

The above process is iterated for all resolution levels. The process is stopped either when the user indicates that the visual level is adequate or the entire image has been sent resulting in a perfect, loss-less, replication of the original image on the user's screen.

The type of temporal prediction, (block D1 in Fig. 4) is selected by the server according to the user's computational capabilities.

If segmentation and/or windowing and/or lossy compression was performed on the images, the user can request the server to complete the images to their loss-less representation.

In such a case, the server will compress and transmit the needed information for the user to complete the images to their loss-less version.

At each and every stage the user can choose to broaden the information query requirements, for example, by enlarging the number of images rather than reducing it. In that
5 case, the server will "backtrack" and send the required information to the user.

When the needed information has arrived and been presented to the user, the user is presented with the option to acquire another medical image case from the server.

4. The Man-Machine-Interface

The man-machine interface (MMI) of the user serves as the means by which the user
10 interacts with the system and as a display surface for the medical images. Being a medical images communication network based system, the MMI combines the known and familiar user interface environment of communication software with the tools needed for medical image processing. The goal is to give the user the tools to be part of the described image acquisition process as well as to enable the user to perform tasks regarding the medical image information.
15 The MMI should achieve these goals with minimal to zero intervention or requirements of the user. For that end the entire user software is completely downloaded from the server to the user's machine and for the most part uses part of the communication software already part of the user's machine. All this is done without any user intervention. This also makes user software updates and improvements irrelevant to the end-user. The user software relies heavily
20 on the communication software (e.g. browser) already installed on the user's machine. This enables the user to operate on different machines with different computational and display capabilities. The first task of the user, upon loading the user software into the user's machine is to automatically profile the machine and the network capabilities. This information is then relayed to the server and is used to select various parameters for the rest of the session. This is
25 done without any user intervention.

The MMI, the user is presented with, contains controls which are part of the image acquisition process as well as typical medical image processing tools. The image acquisition tools include case specification tools, image selection tools, resolution level advancement tools, tools for windowing, zooming, panning, graphics and annotations, CINE, and so on.

30 At all times, the user has full information as to what part of the entire medical image case is currently being viewed on the user's display screen. This information includes, but is not limited to, image number, resolution level, loss-less indicator, region of interest indication,

segmentation and window parameters, and so on. By these, the system makes sure the user is fully aware of what exactly is being presented at all times.

While the invention has been particularly shown and described with reference to preferred embodiments thereof, it is to be understood by those skilled in the art that various
5 changes may be made in form and details without departing from the spirit and scope of the invention as defined in the appended claims.

CLAIMS

1. An interactive method for allowing a user to obtain image data for diagnostic purposes from a server having access to stored data, comprising:
5 connecting a user's computer to the server over a communication network;
 receiving from the server image reconstruction software for the user's computer;
 requesting specific image data for transmission from the server to the user's computer;
 progressively transmitting the requested specific image data over the network from the
server to user's computer; and
10 reconstructing a diagnostic quality image, from the image data, using the
reconstruction software.
2. A method according to claim 1, comprising image processing said reconstructed image
using said reconstruction software.
- 15 3. A method according to claim 1 or claim 2, comprising:
 receiving from the server image selection software for the user's computer,
 wherein said image selection software is used for said requesting.
- 20 4. A method according to claim 3, wherein said image selection software controls the
transmission of the image data.
5. A method according to claim 3 or claim 4, wherein said image selection software
displays images from said server.
- 25 6. A method according to any of claims 3-5, wherein said image selection software and
said reconstruction software are received together.
7. A method according to any of claims 3-6, wherein said image selection software and
30 said reconstruction software comprise a single software unit.

8. A method according to any of claims 3-7, wherein said image selection software is operative to stop the transmission of the data.
- 9 A method according to claim 8, wherein said image selection software is operative to
5 restart the transmission of the data, after said stopping.
10. A method according to any of claims 3-9, wherein said image selection software controls processing of data at said server, prior to its transmission.
- 10 11. A method according to claim 10, wherein said processing comprises reducing said data from a large bit-per-pixel ratio to a small bit per pixel ratio.
12. A method according to any of claims 3-11, wherein said image selection software controls said server to selectively transmit only portions of the image data.
- 15 13. A method according to any of claims 3-12, comprising interactively providing user input to said image selection software, to affect said control.
14. A method according to any of claim 3-13, wherein the image selection software
20 comprises application software coded using a device independent network programming language.
15. A method according to any of claim 3-13, wherein the reconstruction software comprises application software coded using a device independent network programming
25 language.
16. A method according to claim 14 or claim 15, wherein said language comprises Java.
17. A method according to claim 14 or claim 15, wherein said language comprises
30 ActiveX.
18. A method according to any of claims 1-17, wherein reconstructing comprises:

reconstructing images of progressively improving quality from the progressively received data;

using the produced improved images of progressively produced quality to decide on processing of the images; and

5 processing said images, prior to the progressively received data being completely received.

19. A method according to any of claims 1-18, wherein reconstructing comprises:

10 reconstructing images of progressively improving quality from the progressively received data;

using the produced improved images of progressively produced quality to decide on processing of the images; and

interactively selecting regions of interests in the images based on said progressively improved images, prior to the progressively received data being completely received.

15

20. An interactive method for allowing a user to obtain image data for diagnostic purposes from a server having access to stored data, comprising:

connecting a user's computer to the server over a communication network;

requesting specific image data for transmission from the server to the user's computer;

20 progressively transmitting the requested specific data over the network to the user's computer;

reconstructing images of progressively improving quality from the progressively received data;

25 using the produced images of progressively produced quality to decide on processing of the images; and

processing said images, prior to the progressively received data being completely received.

21. An interactive method for allowing a user to obtain image data for diagnostic purposes
30 from a server having access to stored data, comprising:

connecting a user's computer to the server over a communication network;

requesting specific image data for transmission from the server to the user's computer;

progressively transmitting the requested specific data over the network to the user's computer;

reconstructing images of progressively improving quality from the progressively received data;

5 using the produced improved images of progressively produced quality to decide on processing of the images; and

interactively selecting regions of interests in the images based on said progressively improved images, prior to the progressively received data being completely received.

10 22. A method according to any of claims 18-21, wherein said image data represents a set of images and wherein said using the produced images to decide comprises using the produced images to decide on processing images which have not yet been received.

23. A method according to any of claims 18-22, comprising deciding on a termination of
15 transmission of said progressive image data, responsive to said reconstructed images.

24. A method according to any of claim 18-23, wherein said processing comprises converting said image data to image data representing an image with fewer bits per pixel.

20 25. A method according to any of claim 18-24, wherein said processing comprises selecting a region of interest of said images.

26. A method according to any of claim 18-25, wherein said processing said images is performed on said image data, at said server, prior to their being transmitted to said user's
25 computer.

27. An interactive method for allowing a user to obtain data for diagnostic purposes from a server having access to stored data, said method comprising:

30 connecting a user's computer to the server over a communication network;
receiving from the server reconstruction software for the user's computer;
requesting specific data for transmission from the server to the user's computer;
progressively transmitting the requested specific data over the network;

progressively receiving the data using the reconstruction software to process the received data and produce images of progressively improving quality; and
using the produced progressively improved images to decide on further transmission of the image data.

5

28. An interactive method for allowing a user to obtain image data for diagnostic purposes from a server having access to stored data, comprising:

connecting a user's computer to the server over a communication network;

requesting specific image data for transmission from the server to the user's computer;

10 reducing the bit-per-pixel ratio of parts of the data being transmitted, responsive to said request; and

transmitting the reduced data.

29. A method according to claim 28, wherein said reduction in bit-per-pixel ratio is
15 performed responsive to user input at said user's computer.

30. A method according to claim 29, wherein said user input comprises selection of an image portion.

20 31. A method according to any of claims 11, 24 or 28-30, wherein reducing the bit-per-pixel ratio comprises:

calculating an average "M" of the gray values in the image and a standard deviation "S" of said gray values; and

25 rescaling these values in the range $[(M-S/2)..(M+S/2)]$ to obtain a new lower number of bits per pixel.

32. A method according to any of claims 11, 24 or 28-30, wherein reducing the bit-per-pixel ratio comprises:

estimating the mean and standard deviation of the gray levels locally; and

30 rescaling these values to obtain a new lower number of bits per pixel.

33. A method according to any of claims 1-32 wherein progressively transmitting the requested data over the network comprises:
- recomposing the image into a pyramidal structure comprised of layers, said layers ranging sequentially from a layer having the least amount of data to a layer having the most data; and
 - transmitting the layers making up the pyramid individually starting with the layer with the least amount of data to enable the user to view the progressively improving image to decide on further transmission of the image.
34. A method according to claim 33, wherein recomposing the image into a pyramidal structure comprises reducing the image to provide the different layers at the transmitting end for progressive transmittal.
35. A method according to claim 34, wherein reducing comprises discarding alternate rows and columns to create an image that is a quarter of the size of the original image.
36. A method according to claim 33, comprising:
- providing a first layer with reduced resolution in the pyramidal structure;
 - providing remaining layers that contain residual values with increased resolution; and
 - progressively receiving the data using to provide images based on the received data of progressively improved resolution.
37. A method according to any of claims 1-36, comprising:
- compressing the requested data transmitted over the network; and
 - decompressing the received required data to provide images.
38. A method according to claim 37, wherein compressing comprises spatially decorrelating the data by predicting each pixel at the current resolution using its spatial casual neighbors.

39. A method according to claim 37, wherein compressing comprises temporally decorrelating each pixel by predicting each pixel value at the current resolution using the values of temporal neighbors from previous images.
- 5 40. A method according to claim 39, wherein a predictor X used in predicting each pixel for a single image is equal to $f(a, b, c)$, wherein a, b and c are previously predicted neighboring pixels.
41. A method according to claim 39, wherein a predictor X used in predicting each pixel
10 for a group of images equals $f(a, b, c, a_1, b_1, c_1, x_1)$ wherein a, b and c are previously predicted neighboring pixels in a same image and a_1, b_1, c_1 and x_1 are corresponding pixels in a previously predicted image of the image group.
42. A method according to claim 37, wherein said compressing and said decompressing
15 use entropy coding and decoding respectively.
43. A method according to claim 42, wherein said entropy coding and decoding are accomplished using Golomb Rice entropy coding and decoding.
- 20 44. A method according to claim 36, comprising using adaptive slicing and entropy coding and decoding of each slice for progressively transmitting the requested specific image data, wherein said entropy coding generates a residual matrix.
45. A method according to claim 44, wherein using adaptive slicing comprises:
25 scanning the obtained residual matrix into a residual vector; and
partitioning the residual vector into variable length sub vectors with a relatively homogeneous probability distribution function.
46. A method according to claim 45, wherein partitioning comprises:
30 estimating the local mean and variance on the sub-vector;
sectioning the vector on high transients; and
coding each sub vector separately.

47. A method according to claim 45 or claim 46, wherein said compression does not increase the size of said data.
- 5 48. A method according to any of claims 1-47 wherein connecting the user computer to the server over a communication network comprises connecting over the Internet.
49. A method according to any of claims 1-47 wherein connecting the user computer to the server over a communication network comprises using a dial up communication system.
- 10 50. A method according to any of claims 1-47 wherein connecting the user computer to the server over the communication network comprises using networking facilities.
51. A method according to any of claims 1-50, wherein the stored data comprises data for a plurality of "postage stamp" images.
- 15 52. A method according to claim 51, comprising using "postage stamp" images as a catalog for selecting those images for which no further data is to be transmitted and those images for which further data is to be transmitted.
- 20 53. A method according to claim 51 or claim 52, wherein said postage stamps comprise a lowest level in a pyramidal representation of said images.
54. A method according to any of claims 1-53, comprising stopping the transmission at the user's request.
- 25 55. A method according to claim 53, comprising restarting the transmission at the user's request.
- 30 56. A method according to any of claim 1-55, wherein progressively transmitting comprising serially transmitting a sequence of images.

57. A method according to any of claim 1-55, wherein progressively transmitting comprising transmitting data operative to reconstruct images of increasing resolution.
58. A method according to any of claims 1-57, wherein progressively transmitting the requested data over the network comprises segmenting an image into background parts and tissue parts, and transmitting the tissue parts first.
59. An interactive method for allowing a user to obtain image data for diagnostic purposes from a server having access to stored data, comprising:
- 10 connecting a user's computer to the server over a communication network;
segmenting an image into background parts and tissue parts; and
transmitting the tissue parts first.
60. A method according to claim 59, comprising requesting said specific image data for transmission from the server to the user's computer.
- 15 61. The method of any of claims 58-60, comprising stopping the transmission before transmitting the background part.
- 20 62. The method of any of claims 58-60, comprising transmitting the background part to achieve loss-less transmission of the image.
63. A method of adaptive slice compression, for compressing progressively transmitted multi-slice image data, which data is progressively transmitted as pyramid layers, comprising
- 25 encoding said data using entropy encoding, which encoding generates a residual matrix;
scanning the obtained residual matrix into a vector; and
partitioning the residual vector into variable length sub vectors with a relatively homogeneous probability distribution function.
- 30 64. A method according to claim 63, wherein partitioning comprises:
estimating the local mean and variance on the vector;

sectioning the vector on high transients; and
coding each sub vector separately.

- 65 An interactive method for allowing a user to obtain image data for diagnostic purposes
5 from a server having access to stored data, comprising:
connecting a user's computer to the server over a communication network;
requesting specific image data for transmission from the server to the user's computer;
transmitting the requested specific image data over the network from the server to
user's computer;
10 stopping said transmission, by command from a user at said user's computer; and
continuing said transmission after a time, on command from said user.
66. A method according to claim 65, wherein said continued transmission is modified by
said user, responsive to images reconstructed from said stopped transmission.
- 15 67. A method according to claim 65 or claim 66, wherein stopping said transmission stops
compression of images at said server.
68. A method according to any of claims 65-67, wherein stopping said transmission
20 comprises stopping said transmission after a partial-resolution representation of the image data
is transmitted.
69. An interactive method for allowing a user to obtain image data for diagnostic purposes
from a server having access to stored data, comprising:
25 connecting a user's computer to the server over a communication network;
receiving from the server image reconstruction software for the user's computer;
requesting specific image data for transmission from the server to the user's computer;
transmitting the requested specific image data over the network from the server to
user's computer; and
30 reconstructing a diagnostic quality image, from the image data, using the
reconstruction software.

1/7

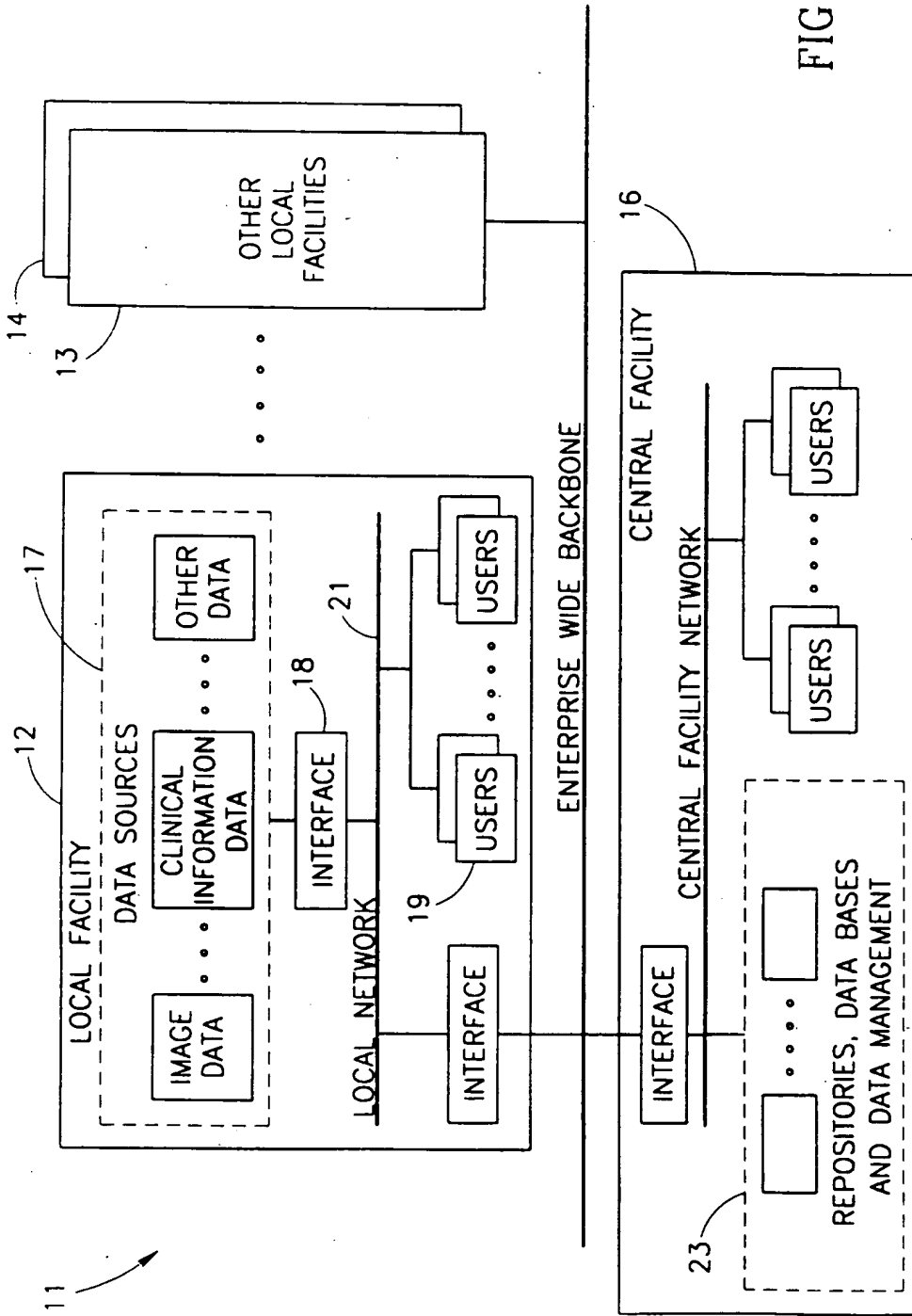

FIG.1

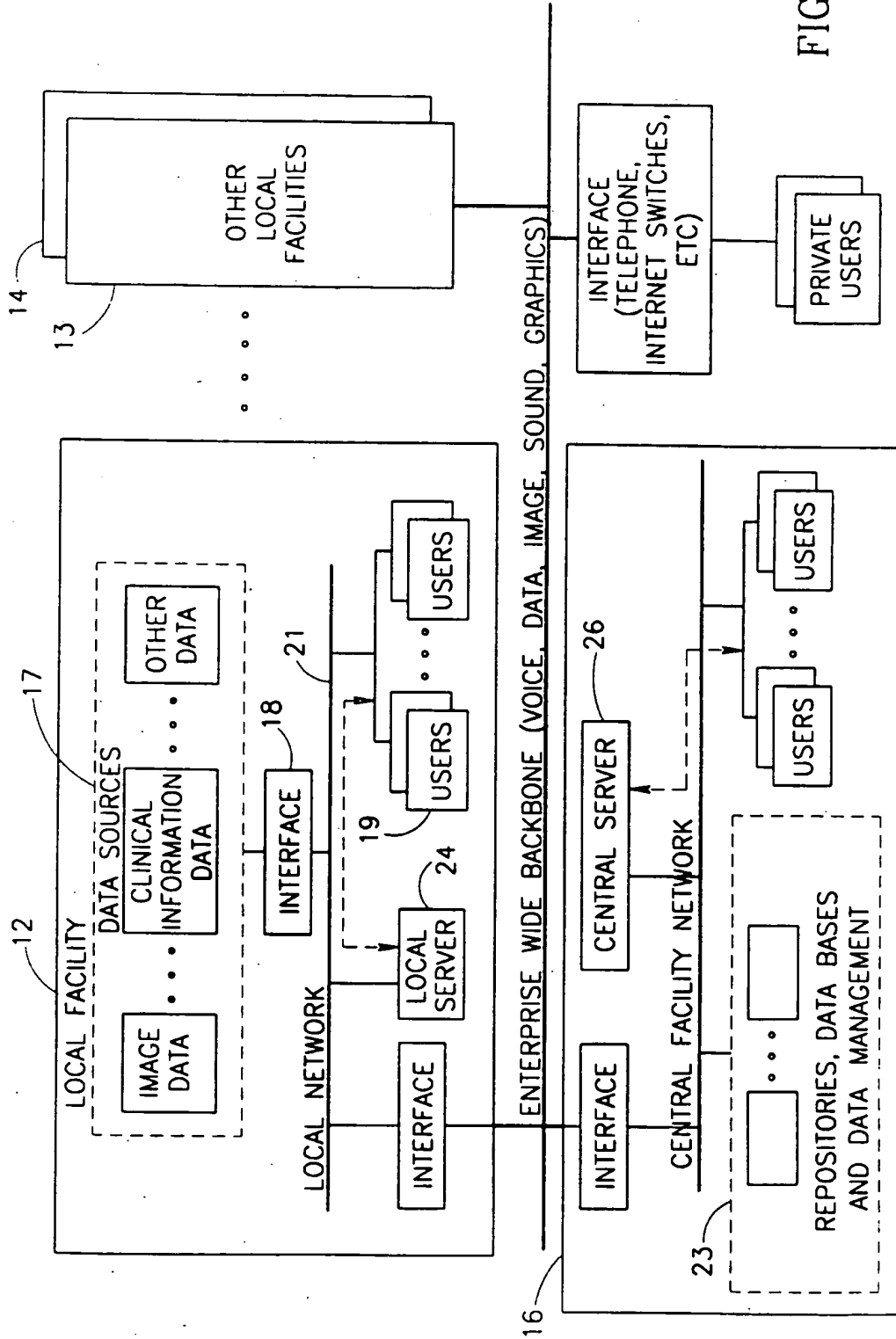

FIG.2

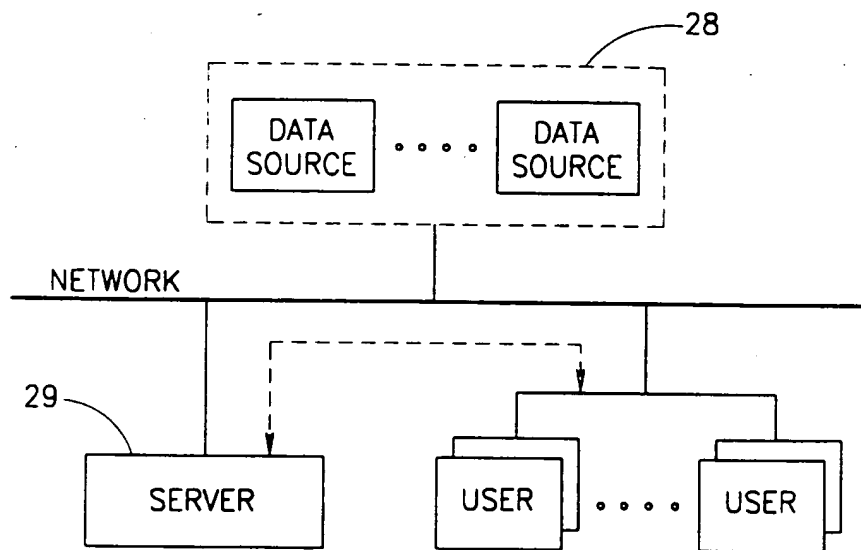

FIG.3

4/7

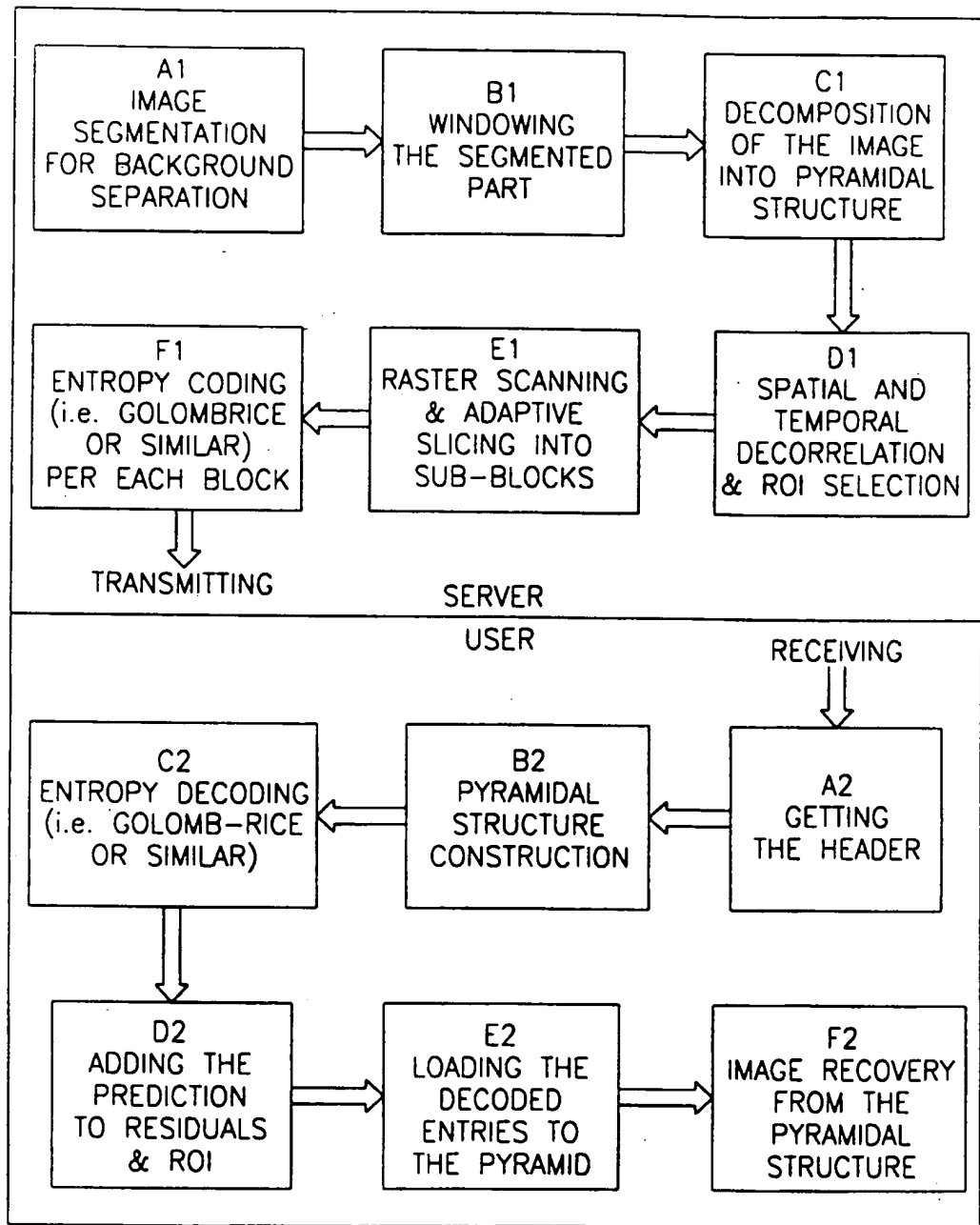

FIG.4

5/7

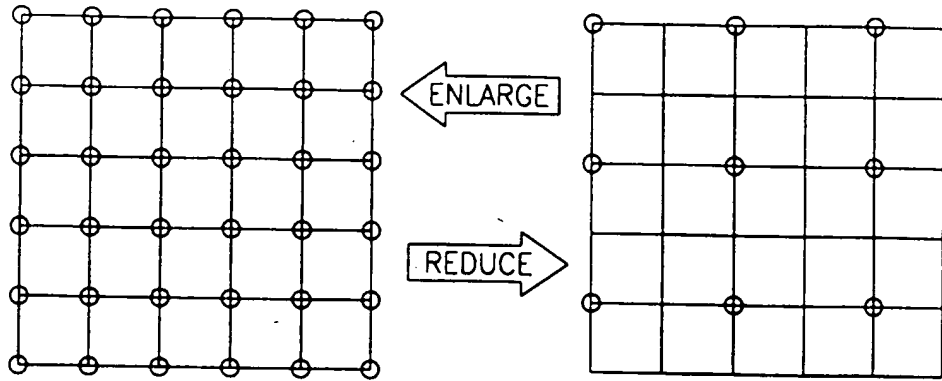

FIG.5

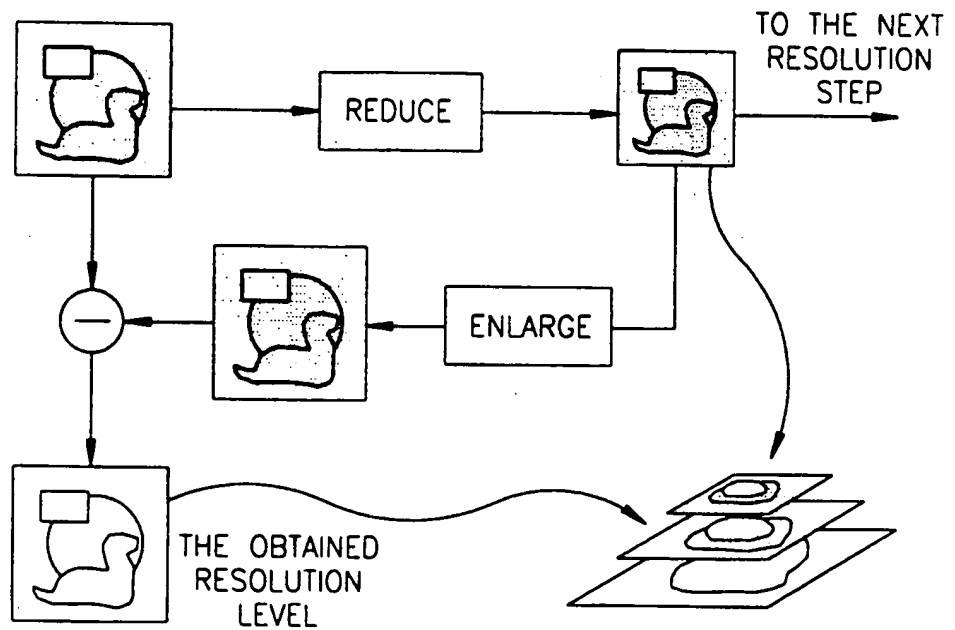

FIG.6

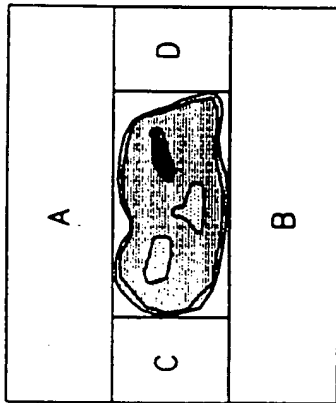

FIG. 7A

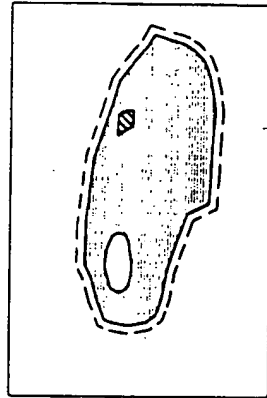

FIG. 7B

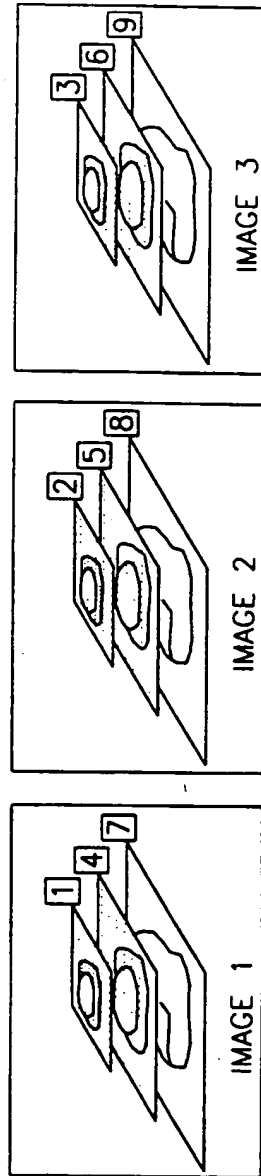

FIG. 8

FIG. 9A

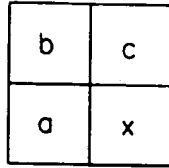

FIG. 9B

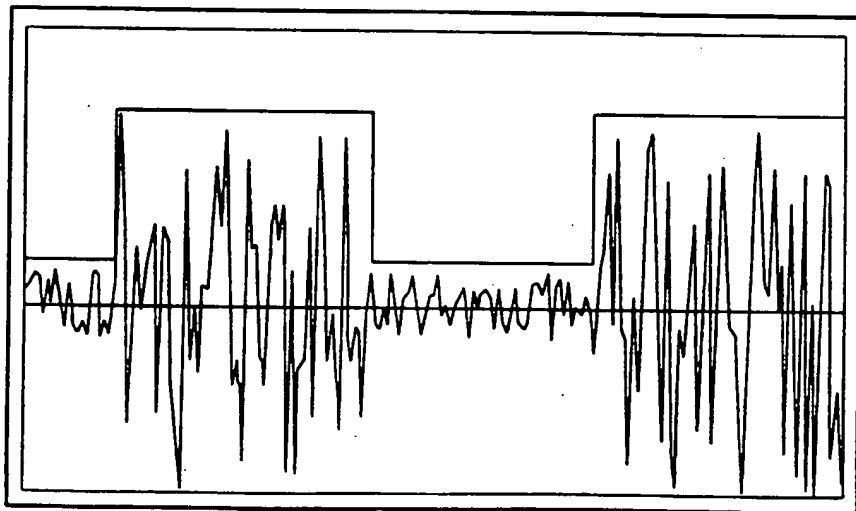
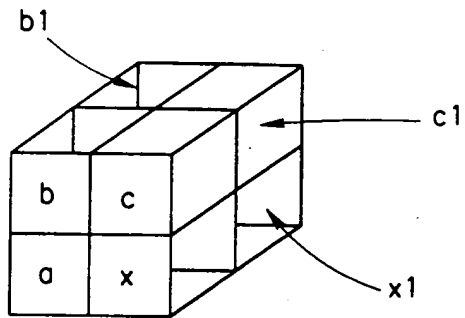

FIG. 10

INTERNATIONAL SEARCH REPORT

Int. l. Application No
PCT/IL 97/00349

A. CLASSIFICATION OF SUBJECT MATTER IPC 6 G06F19/00 H04N1/41		
According to International Patent Classification (IPC) or to both national classification and IPC		
B. FIELDS SEARCHED		
Minimum documentation searched (classification system followed by classification symbols) IPC 6 G06F H04N		
Documentation searched other than minimum documentation to the extent that such documents are included in the fields searched		
Electronic data base consulted during the international search (name of data base and, where practical, search terms used)		
C. DOCUMENTS CONSIDERED TO BE RELEVANT		
Category	Citation of document, with indication, where appropriate, of the relevant passages	Relevant to claim No.
X Y A	HILL F S JR ET AL: "Interactive image query system using progressive transmission" SIGGRAPH '83, DETROIT, MI, USA, 25-29 JULY 1983, vol. 17, no. 3, ISSN 0097-8930, COMPUTER GRAPHICS, 1983, USA, pages 323-330. XP002057163 see the whole document --- -/--	20, 21, 28, 54-57, 65 1, 27, 48-53, 58, 59, 63, 69, 2-19, 22-26, 66-68
<input checked="" type="checkbox"/> Further documents are listed in the continuation of box C.		
<input checked="" type="checkbox"/> Patent family members are listed in annex.		
* Special categories of cited documents :		
A document defining the general state of the art which is not, considered to be of particular relevance *E* earlier document but published on or after the international filing date *L* document which may throw doubts on priority claim(s) or which is cited to establish the publication date of another citation or other special reason (as specified) *O* document referring to an oral disclosure, use, exhibition or other means *P* document published prior to the international filing date but later than the priority date claimed		
T later document published after the international filing date or priority date and not in conflict with the application but cited to understand the principle or theory underlying the invention *X* document of particular relevance; the claimed invention cannot be considered novel or cannot be considered to involve an inventive step when the document is taken alone *Y* document of particular relevance; the claimed invention cannot be considered to involve an inventive step when the document is combined with one or more other such documents, such combination being obvious to a person skilled in the art. *&* document member of the same patent family		
Date of the actual completion of the international search	Date of mailing of the international search report	
27 February 1998	20/03/1998	
Name and mailing address of the ISA European Patent Office, P.B. 5818 Patentlaan 2 NL - 2280 HW Rijswijk Tel: (+31-70) 340-2040, Tr. 31 651 60 01, Fax: (+31-70) 340-3015		Authorized officer Schenkels, P

INTERNATIONAL SEARCH REPORT

International Application No
PCT/IL 97/00349

C (Continuation) DOCUMENTS CONSIDERED TO BE RELEVANT		
Category	Citation of document, with indication, where appropriate, of the relevant passages	Relevant to claim No.
Y	BITTI M G ET AL: "A WWW-based distributed system for medical data analysis and 3D reconstruction" PROCEEDINGS OF THE INTERNATIONAL SYMPOSIUM ON COMPUTER AND COMMUNICATION SYSTEMS FOR IMAGE GUIDED DIAGNOSIS AND THERAPY, PROCEEDINGS OF CAR '96: COMPUTER ASSISTED RADIOLOGY-10TH INTERNATIONAL SYMPOSIUM, PARIS, FRANCE, JUNE 96, ISBN 0-444-82497-9, 1996, AMSTERDAM, NETHERLANDS, ELSEVIER, NETHERLANDS, pages 345-350, XP002057164	1,27, 48-50,69
A	see page 345, line 1 - page 350, line 8; figures 1,2	2-19,59, 63
Y	WO 96 29818 A (IMPERIAL COLLEGE ;BHARATH ANIL (GB); KITNEY RICHARD (GB)) 26 September 1996	51-53
A	see page 1, line 3 - page 5, line 8	20-22, 28,65
Y	XU M ET AL: "Adaptive, segmented attenuation correction for whole-body PET imaging" IEEE TRANSACTIONS ON NUCLEAR SCIENCE, FEB. 1996, IEEE, USA, vol. 43, no. 1, pt.2, ISSN 0018-9499, pages 331-336, XP002057165 see page 331, left-hand column, line 1 - page 332, right-hand column, line 25; figures 1-3	58,59
Y	NOSRATINIA A ET AL: "INTERFRAME CODING OF MAGNETIC RESONANCE IMAGES" IEEE TRANSACTIONS ON MEDICAL IMAGING, vol. 15, no. 5, October 1996, pages 639-647, XP000640705 see page 639, left-hand column, line 1 - page 640, left-hand column, line 12	63

INTERNATIONAL SEARCH REPORT

Information on patent family members

International Application No

PCT/IL 97/00349

Patent document cited in search report	Publication date	Patent family member(s)	Publication date
WO 9629818 A	26-09-96	AU 5012296 A	08-10-96